

# LeCont

Costruttore	LeCont s.r.l.	
Marca	LeCont	
Modello	Slick 10x4.50-5 LH-03	
Categoria	Groupe 2 / Group 2	
Numero di pagine	4	



FOTO DEL PNEUMATICO MONTATO

DISEGNO DEL BATTISTRADA

Timbro e firma del costruttore

  
**LeCont s.r.l.**  
 PRESIDENTE CONS. DI AMMINISTR.

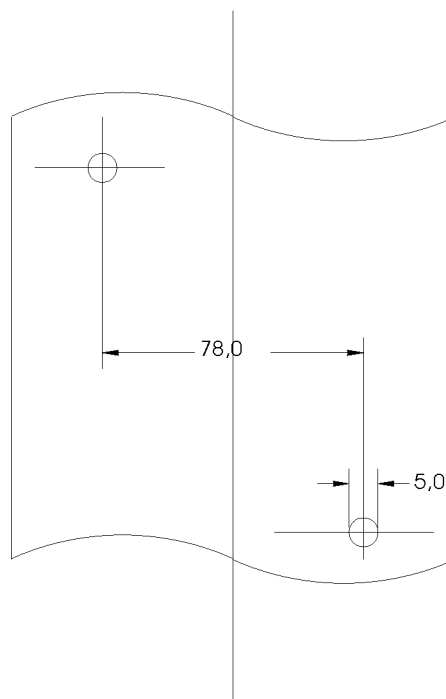
Timbro e firma della ASN

<b>DESCRIZIONE TECNICA</b>			
<i>At a temperature of 23°C +/- 2°C and with a humidity of 50% +/-5%</i>			
<b>Pt</b>	<b>Descrizione</b>	<b>Valeurs</b>	<b>Tolérances</b>
1	<i>Dimensione</i>	10x4.50-5	-
2	<i>Nome del tipo di gomma</i>	LH 03	-
3	<i>Pressione di utilizzo</i>	0,6 bar	+/- 0,3 bar
4	<i>Massima pressione di gonfiaggio</i>	4,00 bar	Max
5	<i>Massima capacità di carico</i>	80 Kg	Max
6	<i>Massima velocità</i>	200 Km/h	Max
7	<i>Profondità del profilo</i>	3,3 mm	+/- 0,5 mm
8	<i>Peso in grammi</i>	1050 Kg	+/- 10 %
9	<i>Numero di tele</i>	2	-
10	<i>Spessore del battistrada</i>	4,5 mm	+/- 1,0 mm
11	<i>Numero di spie d'usura</i>	6	-
12	<i>Materiale della carcassa</i>	Polyestere	-
13	<i>Angolo della carcassa</i>	30°	+/- 5°
14	<i>Pneumatico Tubeless</i>	Yes	-
15	<i>Durezza del battistrada (ISO 48/94 )</i>	54,0	<b>+/- 5 IRHD</b>
16	<i>Classificazione</i>	HARD	

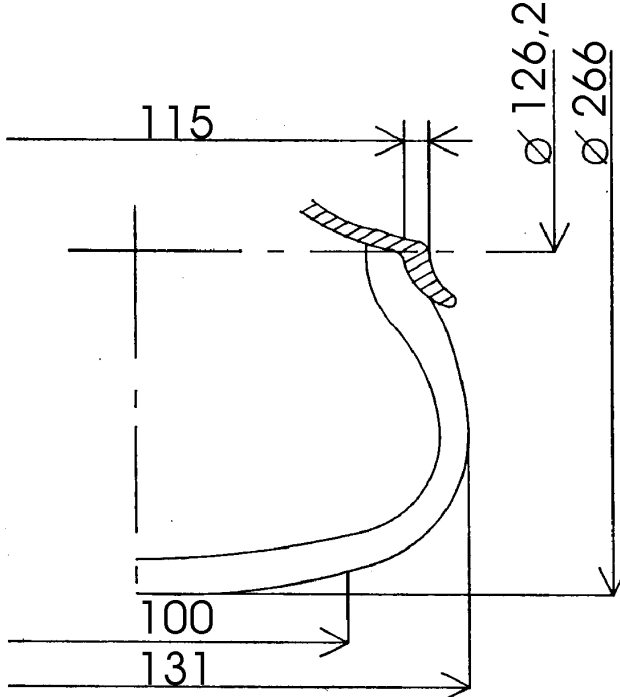
B	DISEGNO DELLA SEZIONE DEL PNEUMATICO MONTATO SUL CERCHIO	B												
		<p style="text-align: center;"><i>Tolleranze</i></p> <table border="1"> <thead> <tr> <th>mm</th> <th>mm</th> </tr> </thead> <tbody> <tr> <td>Diam. 126,2</td> <td>+0,0 -1,0</td> </tr> <tr> <td>Diam. 266,0</td> <td>+/- 6,0%</td> </tr> <tr> <td>115</td> <td>+/- 2,0</td> </tr> <tr> <td>131</td> <td>+/-6,0%</td> </tr> <tr> <td>100</td> <td>+/-5,0%</td> </tr> </tbody> </table>	mm	mm	Diam. 126,2	+0,0 -1,0	Diam. 266,0	+/- 6,0%	115	+/- 2,0	131	+/-6,0%	100	+/-5,0%
		mm	mm											
		Diam. 126,2	+0,0 -1,0											
Diam. 266,0	+/- 6,0%													
115	+/- 2,0													
131	+/-6,0%													
100	+/-5,0%													
<i>Commenti</i>														
<i>Commenti</i>														

**Cerchio standard 5"**

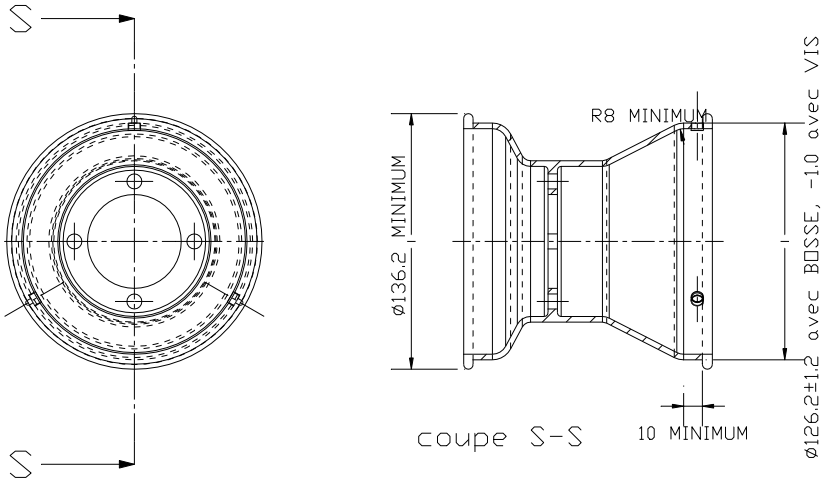

C	FOTO E SCRITTE		
	<i>Foto del pneumatico montato sul cerchio</i>		
	<i>Testo</i>	<i>Altezza</i>	<i>Spessore</i>
	<p><b>LeCONT</b>  (Printed)</p>		
	<p>10X4.50-5</p>	11.0	0.7
	<p>LH 03</p>	7,0	2.0
	<p>FOR RACING PURPOSE ONLY</p>	4.5	0.5
	<p>MAX INFLATION PRESSURE 4,0 KG/CM<sup>2</sup> – 58 PSI</p>	4.5 4.5	0.5 0.5
	<i>Foto del pneumatico montato sul cerchio</i>		
	<i>Testo</i>	<i>Altezza</i>	<i>Spessore</i>
	<p><b>LeCONT</b> </p>	17.0	0.8
	<p>TUBELESS</p>	6.5	0.7
	<p>10X4.50-5</p>	11.0	0.7
	<p>FOR RACING PURPOSE ONLY</p>	4.5	0.5
	<p>MAX INFLATION PRESSURE 4,0 KG/CM<sup>2</sup> – 58 PSI MADE IN ITALY</p>	4.5 4.5	0.5 0.5