

HOMOLOGATION FORM

LH 04

TYRE

<i>Tyre Manufacturer</i>	LeCont s.r.l.	
<i>Make</i>	LeCont	
<i>Model</i>	WET 11x5.00-5 LH 04	
<i>Category</i>	Groupe 2 / Group 2	
<i>Validity of the homologation</i>		
<i>Number of pages</i>	4	

This Homologation Form reproduces descriptions, illustrations and dimensions of the tyre

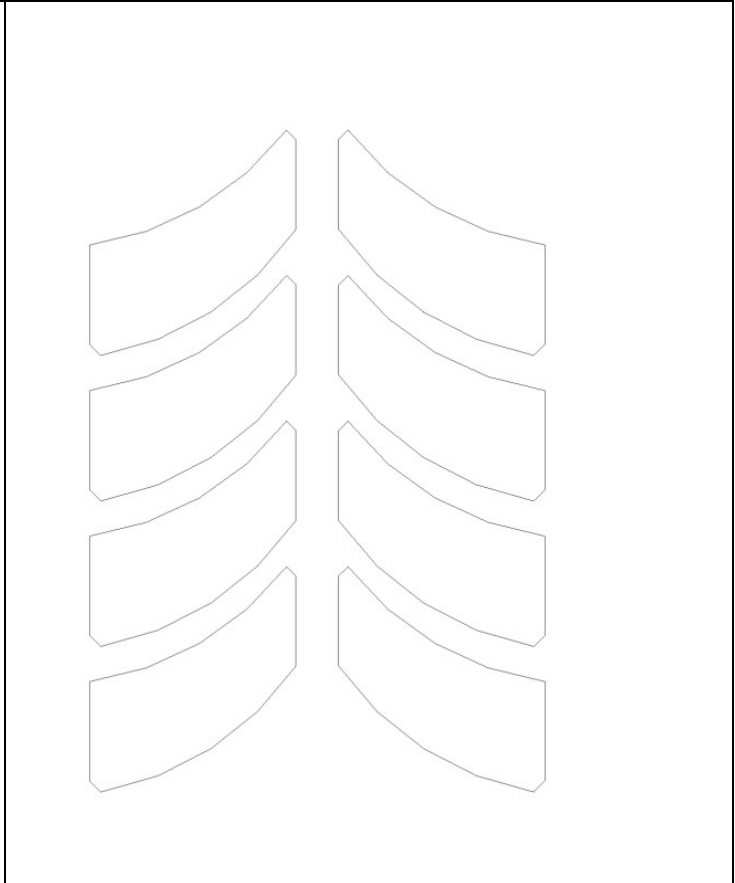

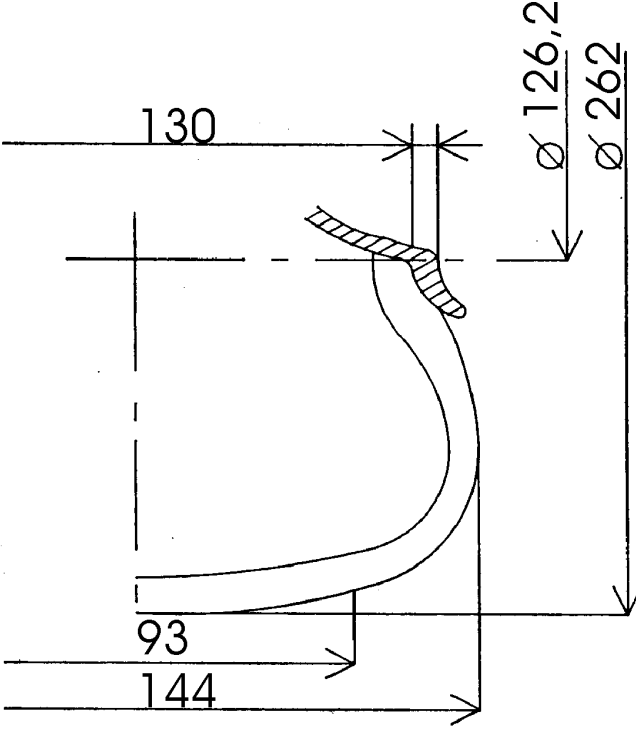

PHOTO OF THE TYRE FITTED TO THE RIM

TREAD DESIGN DRAWING



<i>Signature and stamp of the Manufacturer</i>	<i>Signature and stamp of the ASN</i>
	

TECHNICAL DESCRIPTIONS			
At a temperature of 23 °C +/- 2 °C and with a humidity of 50% +/-5%			
Pt	Descriptions	Valeurs	Tolérances
1	<i>Dimensions</i>	11x5.00-5	-
2	<i>Tread compound designation</i>	LH 04	-
3	<i>Service pressure</i>	0,9 bar	+/- 0,3 bar
4	<i>Maximum inflation pressure</i>	4,00 bar	Max
5	<i>Maximum load capacity</i>	100 Kg	Max
6	<i>Maximum speed</i>	160 Km/h	Max
7	<i>Depth of tread</i>	3,5 mm	+/- 0,5 mm
8	<i>Weight in grams</i>	1,050 Kg	+/- 10 %
9	<i>Numbers of plies</i>	2	-
10	<i>Tread thickness</i>	4,5 mm	+/- 1,0 mm
11	<i>Number of tread wear indicators</i>	6	-
12	<i>Carcass material</i>	Polyestere	-
13	<i>Angle of tyre canvass</i>	29°	+/- 5°
14	<i>Tubeless tyre</i>	Yes	-
15	<i>Superficial tread hardness (ISO 48/94 – 2 samples of 2mm thickness)</i>	55,0	+/- 5 IRHD
16	<i>Classification</i>	WET	

B	DRAWING OF CROSS SECTION AND DIMENSIONS OF TYRE FITTED TO A RIM	B												
		<p style="text-align: center;"><i>Tolerances</i></p> <table border="1"> <thead> <tr> <th>mm</th> <th>mm</th> </tr> </thead> <tbody> <tr> <td>Diam. 126,2</td> <td>+0,0 -1,0</td> </tr> <tr> <td>Diam. 262,0</td> <td>+/- 6,0%</td> </tr> <tr> <td>130</td> <td>+/- 3,0</td> </tr> <tr> <td>144</td> <td>+/-5,0%</td> </tr> <tr> <td>93</td> <td>+/-5,0%</td> </tr> </tbody> </table>	mm	mm	Diam. 126,2	+0,0 -1,0	Diam. 262,0	+/- 6,0%	130	+/- 3,0	144	+/-5,0%	93	+/-5,0%
mm	mm													
Diam. 126,2	+0,0 -1,0													
Diam. 262,0	+/- 6,0%													
130	+/- 3,0													
144	+/-5,0%													
93	+/-5,0%													
		<i>Comments</i>												

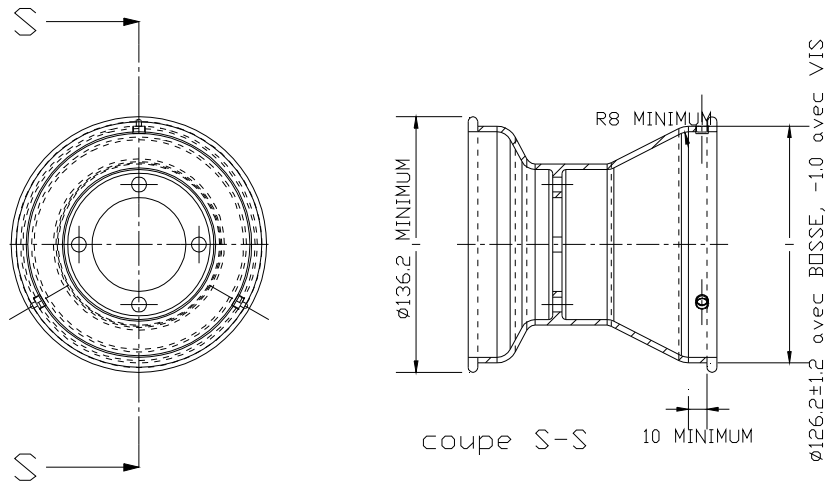
Standardised 5" rim



C	<i>PHOTOS AND INSCRIPTIONS</i>	<i>Only inscriptions which will not change during production are mentioned below.</i>		
C				
<i>Photo of tyre external side wall</i>		<i>Inscriptions on tyre external side wall</i>		
		<i>Text</i>	<i>Height</i>	<i>Stroke</i>
		<p style="font-size: 1.2em; margin: 0;">LeCONT </p> <p style="margin: 0;"><i>TUBELESS</i></p> <p style="margin: 0;"><i>11 X 5.00 - 5</i></p> <p style="margin: 0; text-align: center;">■</p> <p style="margin: 0; text-align: center;">■</p> <p style="margin: 0; text-align: center;">■</p> <p style="margin: 0; text-align: center;">■</p>	<p>18,0</p> <p>7,0</p> <p>11,0</p> <p>4,5</p> <p>4,5</p> <p>4,5</p> <p>4,5</p>	<p>3,0</p> <p>0,8</p> <p>0,8</p> <p>0,5</p> <p>0,5</p> <p>0,5</p> <p>0,5</p>
<i>Photo of tyre internal side wall</i>		<i>Inscriptions on tyre internal side wall</i>		
		<i>Text</i>	<i>Height</i>	<i>Stroke</i>
		<p style="font-size: 1.2em; margin: 0;">LeCONT </p> <p style="margin: 0;"><i>(Printed)</i></p> <p style="margin: 0;"><i>LH04</i></p> <p style="margin: 0;"><i>11 X 5.00 - 5</i></p> <p style="margin: 0; text-align: center;">■</p> <p style="margin: 0; text-align: center;">■</p> <p style="margin: 0; text-align: center;">■</p>	<p>8,0</p> <p>11,0</p> <p>4,5</p> <p>4,5</p> <p>4,5</p>	<p>2,0</p> <p>0,8</p> <p>0,5</p> <p>0,5</p> <p>0,5</p>