

## TYRE SPECIFICATIONS

2022-2026 AUSTRALIAN KARTING ASSOCIATION LTD. (Karting Australia)

### TYRE TENDER

<i>Tyre Manufacturer</i>	LeCont srl
<i>Tyre Supplier</i>	Kingarth Pty Ltd
<i>Make</i>	LeCont
<i>Model</i>	LH03 AUS 10x4.50-5
<i>Competition Group / Class/es</i>	Groups 1B
<i>Number of pages</i>	4
<i>Number of appended pages</i>	0

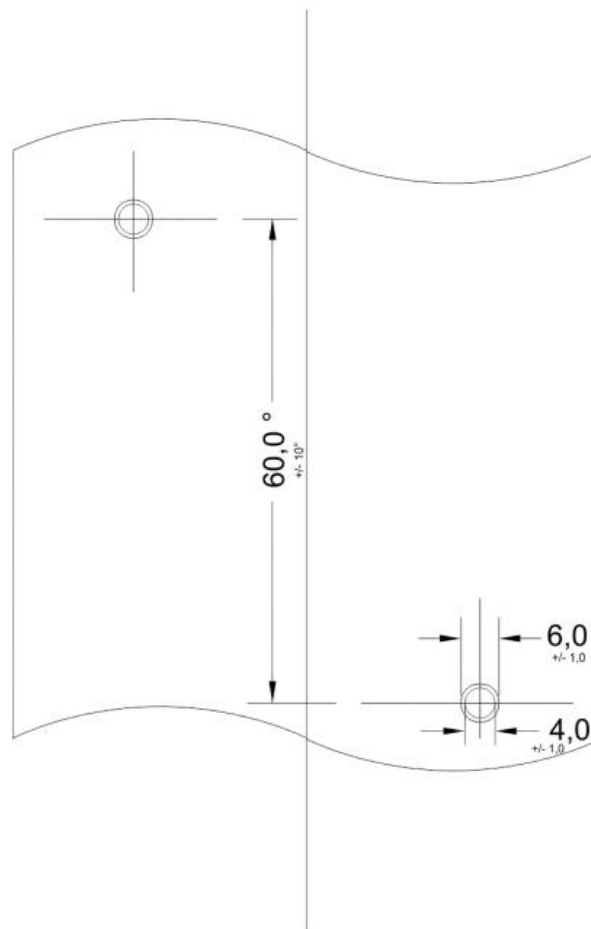

TREAD DESIGN DRAWING

## TECHNICAL DESCRIPTIONS

At a temperature of 23°C +/- 2°C and with a humidity of 50% +/-5%

Pt	Descriptions	Value		Tolerances
1	Dimensions	10x4.50-5		-
2	Tread compound designation	LH03 AUS		-
3	Service pressure	0.7 bar		+/- 0,3 bar
4	Maximum inflation pressure	4.0 bar		Max
5	Recommended Inflation pressure	-----		
6	Maximum load capacity	80 kg		Max
7	Maximum speed	200 km/h		Max
8	Depth of tread	3.6 mm		+/- 0,5 mm
9	Weight in grams	1050 gr		+/- 10 %
10	Numbers of ply	2		-
11	Tread thickness	4.6 mm		+/- 1,0 mm
12	Number of tread wear indicators	6		-
13	Carcass material	Polyester		-
14	Angle of tyre canvass	31°		+/- 5°
15	Canvass thread type (According to ISO)	1670		-
16	Tubeless tyre	Yes		-
17	Superficial tread hardness (ISO 48 :2010 – 2 samples of 2mm thickness)	55.0		+/- 5 DIDC - IRHD
18	Classification (According to ISO 37:2005 – 300%) (DELETE OR ADJUST THOSE NOT APPROPRIATE)	<del>SOFT</del>	<del>MEDIUM</del>	HARD

B

DRAWING OF CROSS SECTION AND DIMENSIONS OF TYRE FITTED TO A RIM

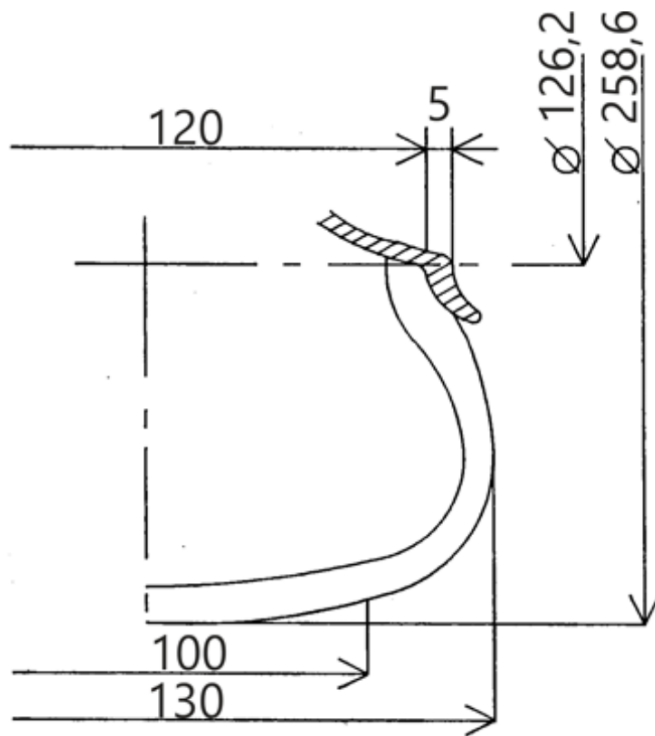

Dimensions / Tolerances

Ø 258.6 mm	+/- 6.0 mm
Ø 126.2 mm	+0/- 1.0 mm
130.0 mm	+/- 6.0 mm
100.0 mm	+/- 5.0 mm
120.0 mm	+/- 2.0 mm

Comments

(\*) Dimension according to the CIK-FIA technical Drawing n° 4 – standardized 5" rim

**Standardised 5" rim**

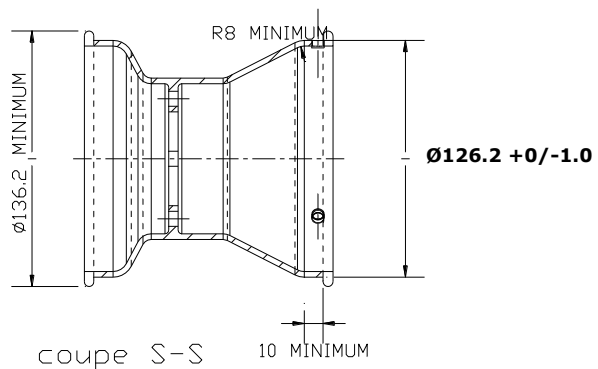
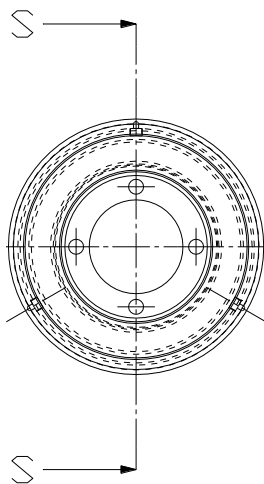

C	PHOTOS AND INSCRIPTIONS	Only inscriptions which will not change during production are mentioned below.		
<i>Photo of tyre external side wall</i>		<i>Inscriptions on tyre external side wall</i>		
		Text	Height (mm)	Stroke (mm)
		<p style="text-align: center;"><b>LECONT  AUS</b></p> <p style="text-align: center;">Printed colorful Light Grey lettering</p> <hr/> <p style="text-align: center;">Barcode</p> <hr/> <p style="text-align: center;">FOR RACING PURPOSE ONLY</p> <p style="text-align: center;">MAX INFLATION PRESSURE 4.0 BAR – 58 PSI</p> <p style="text-align: center;">TUBELESS</p> <hr/>	4.5 mm	0.8 mm
<i>Photo of tyre internal side wall</i>		<i>Inscriptions on tyre internal side wall</i>		
		Text	Height (mm)	Stroke (mm)
		<p style="text-align: center;"><b>LeCont </b></p> <hr/> <p style="text-align: center;">Barcode</p> <hr/> <p style="text-align: center;">FOR RACING PURPOSE ONLY</p> <p style="text-align: center;">MAX INFLATION PRESSURE 4.0 BAR – 58 PSI</p> <p style="text-align: center;">TUBELESS</p> <hr/> <p style="text-align: center;">10x4.50-5 LH03</p>	18-10 mm	3.5-2.5 mm