

TYRE SPECIFICATIONS

2022-2026 AUSTRALIAN KARTING ASSOCIATION LTD. (Karting Australia)

TYRE TENDER

<i>Tyre Manufacturer</i>	LeCont srl
<i>Tyre Supplier</i>	Kingarth Pty Ltd
<i>Make</i>	LeCont
<i>Model</i>	LH03 AUS 11x7.10-5
<i>Competition Group / Class/es</i>	Groups 1B
<i>Number of pages</i>	4
<i>Number of appended pages</i>	0

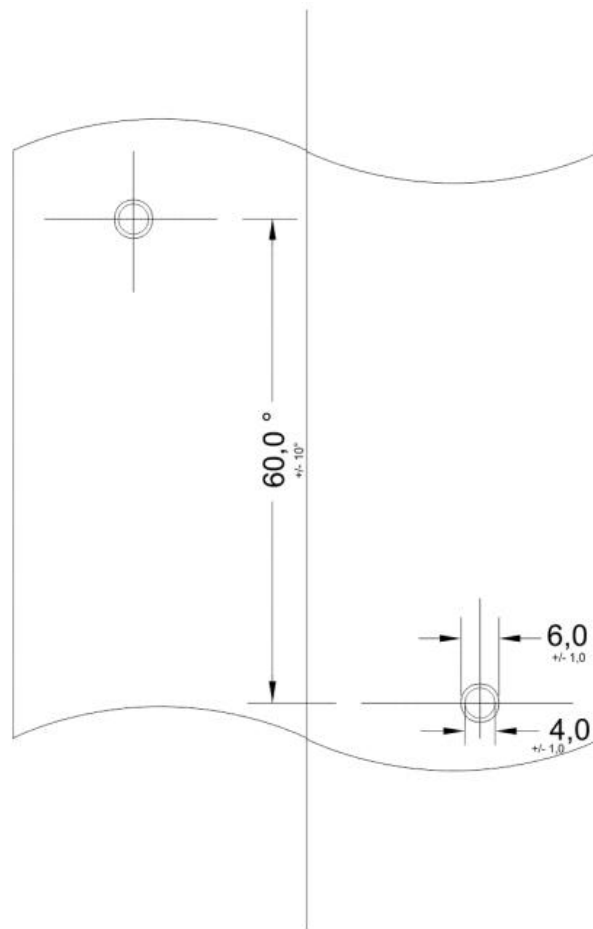

TREAD DESIGN DRAWING

TECHNICAL DESCRIPTIONS

At a temperature of 23°C +/- 2°C and with a humidity of 50% +/-5%

Pt	Descriptions	Value		Tolerances
1	Dimensions	11x7.10-5		-
2	Tread compound designation	LH03 AUS		-
3	Service pressure	0.7 bar		+/- 0,3 bar
4	Maximum inflation pressure	4.0 bar		Max
5	Recommended Inflation pressure	-----		
6	Maximum load capacity	100 kg		Max
7	Maximum speed	200 km/h		Max
8	Depth of tread	4.0 mm		+/- 0,5 mm
9	Weight in grams	1580 gr		+/- 10 %
10	Numbers of ply	2		-
11	Tread thickness	4.6 mm		+/- 1,0 mm
12	Number of tread wear indicators	6		-
13	Carcass material	Polyester		-
14	Angle of tyre canvass	30°		+/- 5°
15	Canvass thread type (According to ISO)	1670		-
16	Tubeless tyre	Yes		-
17	Superficial tread hardness (ISO 48 :2010 – 2 samples of 2mm thickness)	55.0		+/- 5 DIDC - IRHD
18	Classification (According to ISO 37:2005 – 300%) (DELETE OR ADJUST THOSE NOT APPROPRIATE)	SOFT	MEDIUM	HARD

B

DRAWING OF CROSS SECTION AND DIMENSIONS OF TYRE FITTED TO A RIM

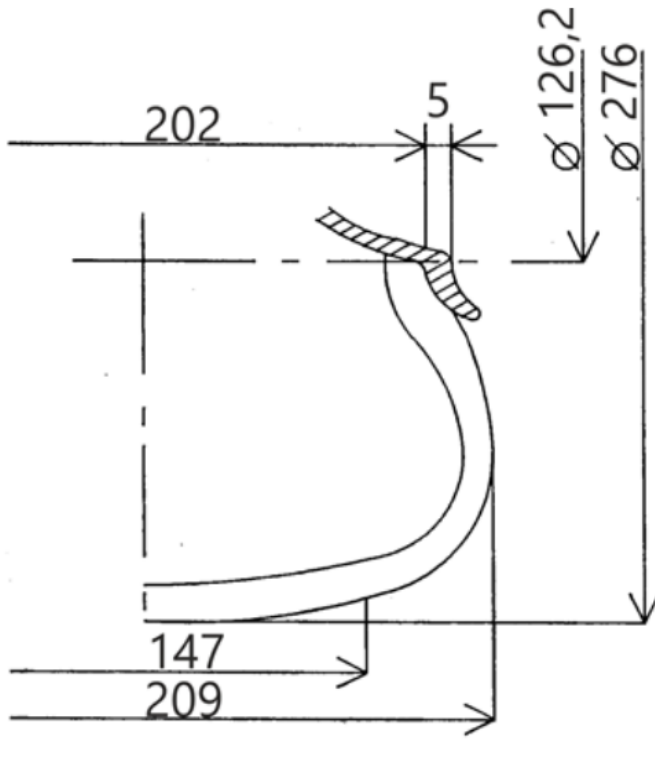

Dimensions / Tolerances

Ø 276.0 mm	+/- 6.0 mm
Ø 126.2 mm	+0/- 1.0 mm
202.0 mm	+/- 2.0 mm
208.0 mm	+/- 6.0 mm
147.0 mm	+/- 5.0 mm

Comments

(*) Dimension according to the CIK-FIA technical Drawing n° 4 – standardized 5" rim

Standardised 5" rim

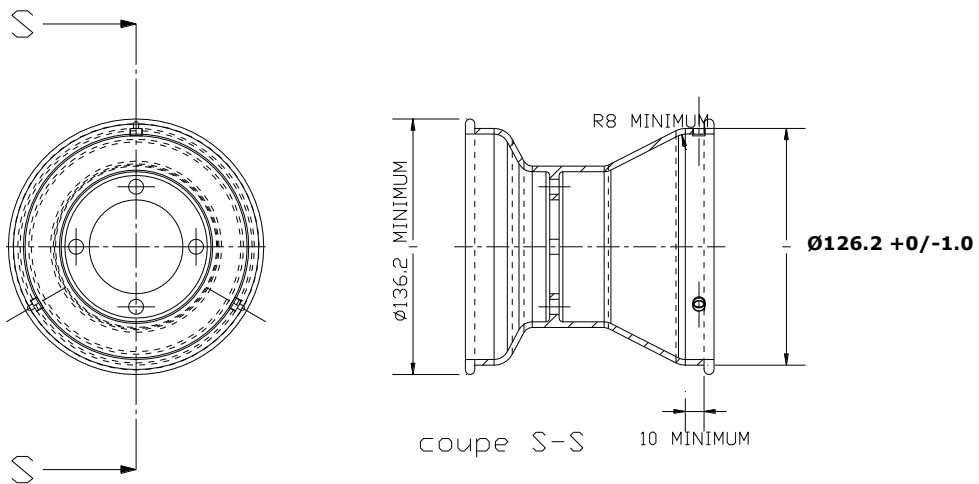

C	PHOTOS AND INSCRIPTIONS	<i>Only inscriptions which will not change during production are mentioned below.</i>		
<i>Photo of tyre external side wall</i>		<i>Inscriptions on tyre external side wall</i>		
		Text	Height (mm)	Stroke (mm)
				<p>LECONT AUS</p> <p>Printed colorful Light Grey lettering</p> <hr/> <p>Barcode</p> <hr/> <p>FOR RACING PURPOSE ONLY</p> <p>MAX INFLATION PRESSURE 4.0 BAR – 58 PSI</p> <p>TUBELESS</p>
<i>Photo of tyre internal side wall</i>		<i>Inscriptions on tyre internal side wall</i>		
		Text	Height (mm)	Stroke (mm)
				<p>LeCont</p> <hr/> <p>Barcode</p> <hr/> <p>FOR RACING PURPOSE ONLY</p> <p>MAX INFLATION PRESSURE 4.0 BAR – 58 PSI</p> <p>TUBELESS</p> <hr/> <p>11x7.10-5 LH03</p>
			4.5 mm	0.8 mm
			8.0 mm	1.5 mm